

AN APPROACHMENT TO GROUP PROCESSES IN FEMALE PROFESSIONAL SPORT

Francisco Miguel Leo; Inmaculada González-Ponce; Diana Amado;
Juan José Pulido; Tomás García-Calvo

Faculty of Sport Sciences, University of Extremadura.

ABSTRACT

Under consideration of the conceptual model of cohesion (Carron & Eys, 2012), this study examined how perceptions of ambiguity and role conflict can predict group cohesion and how it could influence transactive memory and collective efficacy in female sport teams. The participants were 225 professional female soccer players ($M = 22.20$, $SD = 4.61$). Each individual belonged to one of 13 federate teams that participated in the First Division of the Spanish Women's Soccer League. The structural equation model showed that members that perceived greater ambiguity and role conflict perceive less task cohesion with their teams. Additionally, individuals who feel more united with their team and are willing to work in a collaborative manner state that a greater transactive memory in regards to performing tasks and greater collective efficacy in realizing these tasks exist. The results suggest that the group leaders in female sports teams will have to make an effort to define the roles of each member of the team to improve the union and group work, because these factors are linked to the capacity of sharing knowledge among group members and the confidence in abilities when facing team work.

Key Words: role, cohesion, transactive memory, collective efficacy, group dynamics

UNA APROXIMACIÓN A LOS PROCESOS DE GRUPO EN DEPORTE FEMENINO PROFESIONAL

RESUMEN

Bajo la perspectiva del modelo conceptual de la cohesión (Carron y Eys, 2012), este estudio examinó cómo las percepciones de ambigüedad y conflicto de rol pueden predecir la cohesión del grupo y cómo ésta variable podría influir en la memoria transactiva y la eficacia colectiva en equipos de fútbol femeninos. Los participantes fueron 225 futbolistas profesionales de género femenino ($M = 22.20$, $DT = 4.61$). Cada jugadora pertenecía a uno de los 13 equipos federados que participan en la Primera División de la Liga Española de Fútbol femenino. El modelo de ecuaciones estructurales mostró que los miembros que perciben una mayor ambigüedad y conflicto de rol perciben una menor cohesión a la tarea en sus equipos. Además, las jugadoras que se sienten más unidas a su equipo y están dispuestas a trabajar de forma colaborativa muestran una mayor memoria transactiva en lo que respecta al desarrollo de tareas y una mayor eficacia colectiva en la realización de éstas tareas. Los resultados sugieren que los líderes del grupo en equipos deportivos femeninos tendrán que hacer un esfuerzo para definir las funciones de cada jugadora del equipo para mejorar la unión y el trabajo en grupo, debido a que estos factores están relacionados con la capacidad de compartir el conocimiento entre los miembros del grupo y la confianza en las habilidades del grupo a la hora de realizar trabajos en equipo.

Palabras clave: rol, cohesión, memoria transactiva, eficacia colectiva, dinámicas de grupo

Correspondence:

Francisco Miguel Leo Marcos
Faculty of Sport Sciences, University of Extremadura.
Av/ de la Universidad s/n 10071, Cáceres, Spain
franmilema@unex.es

Submitted: 18/05/2016

Accepted: 30/05/2016

INTRODUCTION

Based on the conceptual model of cohesion by Carron (Carron & Eys, 2012), numerous studies have been realized that confirmed how different antecedents can influence the union, development and functioning of a group (Filho, Tenenbaum, & Yang, 2015; Fransen et al., 2015; Eys et al., 2015). Until now, most of the works about the importance of the group processes in performance have been based on an analytic approach in which the relationships between two or three features of performance were examined (Heuzé, Raimbault, & Fontayne, 2006; Kozub & McDonnell, 2000; Spink, 1990). However, Carron and Eys (2012) argued that it would be necessary to develop investigations employing several of the most important group processes (i.e., cohesion, collective efficacy, role perceived, transactive memory), in order to have a more holistic view of the psychological aspects of sports teams and explain what variables can help a team to be more effective (Fuster-Parra, García-Mas, Ponseti, & Leo, 2015).

For this reason, this study seeks to examine the group processes that take place in professional female teams in sport from a point of view that takes the conceptual model of cohesion into account (Carron & Eys, 2012). The task at hand is to establish role ambiguity and role conflict as either favouring or weakening factors in group cohesion, it being a fundamental antecedent of transactive memory and collective efficacy (Figure 1).

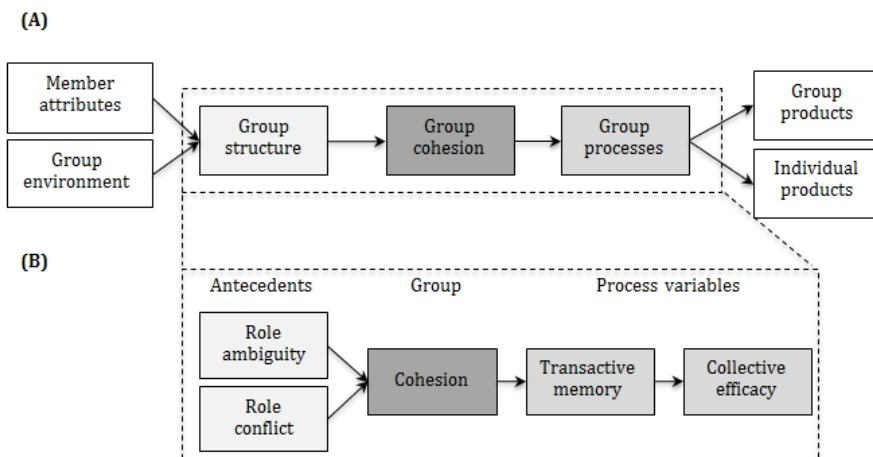

FIGURE 1: (A) A conceptual framework for the study of sport teams (Carron & Eys, 2012).
(B) Proposed nomological network of team dynamics in sports.

In this sense, the idea to define this study within the context of professional athletes was born out of the importance to achieve optimization of resources to obtain better performance. Sport teams clearly represent the idea of a group

formed to be productive and coaches try to form a team of unified work, that shares its knowledge, with clearly defined functions, and with great confidence in its possibilities. Furthermore, sport offers a unique special feature, because teams are formed with people of the same sex, which can affect or condition the relations between group members and the productivity of a group (Carron & Eys, 2012), therefore it is interesting to investigate this collective and draw conclusions that can be applied to other areas.

From the analysis of group processes, Carron and Eys (2012) discovered that roles can be a clear indicator of the presence of the psychological structure in a group and therefore can affect the levels of cohesion of a team. Furthermore, the importance that the optimization of resources has gained in the athletic and work context, explains the inclusion of role ambiguity and role conflict in different investigation studies as a way to optimize the functioning of a group (Beauchamp & Bray, 2001; Beauchamp, Bray, Fielding, & Eys, 2005; Bosselut, McLaren, Eys, & Heuzé, 2012; Cunningham & Eys, 2007; Leo González-Ponce, Sánchez-Miguel, Ivarsson, & García-Calvo, 2015).

Role ambiguity, defined as lack of clear and coherent information about a particular function, as well as role conflict, defined as the presence of incoherent expectations within the functions (Beauchamp & Bray, 2001; Tubre & Collins, 2000), have been associated with a greater dissatisfaction at work, less compromise and involvement in the group (Tubre & Collins, 2000). Some of these factors are closely linked to group cohesion, which can lead to believe that when people or members of the group perceive a lack of information or contradictory expectations in regards to their functions, it could provoke the appearance of behavior unfavourable for the group, such as lack of involvement or lack of cooperation and team work to achieve goals. As a matter of fact, several investigators have already indicated the inverse relation between task cohesion and role ambiguity in interdependent teams (Bosselut et al., 2012; Eys & Carron, 2001; Leo, González-Ponce, Sánchez-Miguel et al., 2015). By that, analyzing the relationship of role ambiguity and role conflict in a combined manner in different dimensions of group cohesion can allow to find out in a more profound way how these concepts act and interact and show a behavior guideline for leaders of work groups.

Cohesion has been defined as “a dynamic process that is reflected in the tendency for a group to stick together and remain united in the pursuit of its instrumental objectives and/or for the satisfaction of member affective needs” (Carron, Brawley, & Widmeyer, 1998, p. 213). As mentioned previously, this concept is set within Carron’s conceptual model of cohesion (Carron & Eys, 2012) that states the existence of a series of antecedents (environmental, personal, team related and leadership) that will create a determined type and level of cohesion in a player. This perception of cohesion revolved around two

fundamental focal points, task cohesion - that reflects the degree to which the members of a group work together to achieve mutual goals -, and social cohesion - that reflects the degree to which members of a team empathize with each other and enjoy the companionship of the group (Carron et al., 1998). Additionally, Carron defends the idea that each team member develops a perception of how the group satisfies his/her needs and personal goals - attraction towards the group -, and in relation to how the team functions as a whole - integration into the group-. Therefore in the root of the appreciation that is generated in the players, four different manifestations can be identified: task group integration (GI-T), social group integration (GI-S), individual attraction towards group task (ATG-T) and individual attraction towards social group (ATG-S).

Following Carron's conceptual model, the level of cohesion the members perceived around the work group will trigger a series of consequences that can be divided into individual and collective aspects (Carron et al., 1998). The majority of studies have focused on the positive relation between cohesion and success in sport (Beal, Cohen, Burke, & McLendon, 2003; Carron, Colman, Wheeler, & Stevens, 2002; Eys et al., 2015), and with variables that determine the final performance, such as group effort, coordination and collective efficacy (Carron & Eys, 2012; Filho et al., 2015; Heuzé et al., 2006; Leo, Sanchez-Miguel, Sánchez-Oliva, Amado, & García-Calvo, 2014; Paskevich, Brawley, Dorsch, & Widmeyer, 1999). In this paper, we are going to concentrate on two constructs that are considered to be antecedents of group performance, transactive memory and collective efficacy (Fransen et al., 2015; Heuzé et al., 2006; Myers et al. 2004; Ren & Argote, 2011).

In this way, transactive memory has been popularized recently in scientific literature related to performance in work groups (Lewis & Herndon, 2011). It is defined as the shared knowledge about skills and competencies of members that make up a team for the achievement of collective goals (Hollingshead, 2001). This concept is considered to be particularly relevant to understand the influence of cognition of a group level in the efficacy of teams (Kozlowski & Bell, 2003). Aspects such as communication, coordination and the relationship between colleagues, associated to group cohesion, have proven to favor this shared knowledge (Ren & Argote, 2011). Therefore this leads us to think that if players feel attracted to the group, express great involvement and are prepared to work in this group, it may favor that shared knowledge about what each player knows is established, which means that it would increase intersubjective conscience of the knowledge that others display. As a matter of fact, several investigators have highlighted the need to go in depth in the relation between group processes for the improvement of transactive memory (Hollingshead, 2001; Ren & Argote, 2011).

Lastly, the construct of collective efficacy was first proposed by Bandura (1986) as an extension of self-efficacy theory, and developed by Zaccaro, Blair, Peterson, and Zazanis (1995) who defined it as a “sense of collective competence shared among individuals when allocating, coordinating, and integrating their resources in a successful concerted response to specific situational demands” (p. 309). This confidence in the resources of the group has been associated to the levels of involvement and attraction to the group, meaning that subjects that perceive a great level of union in the group increase the perception about the capacities of the group to face proposed tasks. As a matter of fact, Carron’s model of cohesion (Carron & Eys, 2012) where collective efficacy is identified as one of the most important consequences of cohesion, as well as the model of collective efficacy by Beauchamp (2007) where group cohesion is pointed out as one of the main antecedents in collective efficacy, have confirmed this close relationship between both variables.

In this study, given that collective efficacy as well as transactive memory are included as consequences of group cohesion, the possible associations that could exist between the mentioned variables have to be kept in mind. By that, following the theoretical hypotheses of transactive memory, the efficacy to resolve future tasks is identified as a direct benefit of the development of transactive memory (Kozlowski & Bell, 2003). In other words, transactive memory seems to fuel collective efficacy (Lin & Chou, 2009; Solansky, 2008). Furthermore, previous studies have confirmed that increasing shared knowledge among colleagues improves the confidence in the abilities and capacities of the group (Filho et al., 2015), which can help to achieve an optimal functioning in work groups (Lin & Chou, 2009;). Therefore, it was decided to include both variables in two different levels of analysis, in first place in regards to transactive memory and in second place in regards to collective efficacy (Filho et al., 2015).

The present study

The objective of the study was to extend the existing literature in relation to the conceptual model of cohesion within work groups as well as individual groups such as female sports groups. For this reason, it was decided to include variables that emerged as determinants in cooperate work groups as in the case of role ambiguity and role conflict as antecedents, or transactive memory as consequence of group cohesion. Other determining aspect of the study is to confirm the capacity of transactive memory as mediator between group cohesion and collective efficacy. This concept can help in explaining how existing resources in a work group can be optimized to boost performance and which to this moment has been little addressed in the area of sport.

Along this line, based on Carron's cohesion model the hypothesis was established that role ambiguity and role conflict are shown as antecedents that negatively affect group cohesion. Equally, it was expected that group cohesion positively influences perceived transactive memory among players, which then affects collective efficacy.

METHOD

Participants

The participants were 225 professional female soccer players, which all belonged to one of 13 federate teams that participated in the first division of the Spanish Women's Soccer League and whose age ranged between 15 and 36 years ($M = 22.20$, $SD = 4.61$). All participants had a professional contract receiving a financial compensation for playing on their teams. With regard to playing position, the recruited players participating in this study were 33 goalkeepers, 51 defenders, 72 midfielders, and 59 strikers. The players had an average soccer experience of 12.03 years ($SD = 3.99$).

We recruited all teams from the Spanish Women's Soccer League. From an original total of 230 questionnaires collected, 5 (2.17 %) were deleted due to invalid completion.

Instruments

Role ambiguity. To assess role ambiguity, we used 12-item scale adapted (Leo, González-Ponce, Sánchez-Miguel et al., 2015) from the instrument developed by Beauchamp, Bray, Eys, and Carron (2002), that measures various dimensions –scope of responsibilities, behaviours to fulfil role responsibilities, evaluation of role performance and consequences of not fulfilling role responsibilities–. In this paper, we were interested in the higher order dimension and not in the lower order dimensions. An example of role ambiguity includes “the athlete's knowledge of the extent of his or her responsibilities”. Players responded to all items on a nine-point scale ranging from strongly disagree (1), to strongly agree (9). Thus, higher ratings of agreement indicated greater role clarity and, hence, less role ambiguity. The confirmatory factor analysis (CFA) results with data from our study confirm this factor structure showing acceptable model fit ($\chi^2/df = 3.01$; $CFI = .97$; $TLI = .97$; $RMSEA = .07$; $SRMR = .03$). Furthermore, Cronbach's alpha values were deemed acceptable, for both the four subscales ($\alpha = .82, .83, .82, .81$, respectively) and full scale ($\alpha = .83$), based on the .70 criterion suggested by Nunnally (1994).

Role Conflict. To assess role conflict, we used 6-item scale adapted (Leo, González-Ponce, Sánchez-Miguel et al. 2015) from the instrument developed by Beauchamp and Bray (2001). Examples of role conflict include “I am sometimes

provided with conflicting information of what my role is". Responses were rated on a five-point scale ranging strongly disagree (1) to strongly agree (9). The CFA results with data from our study confirm a factor structure showing acceptable model fit ($\chi^2/df = 2.21$; $CFI = .98$; $TLI = .98$; $RMSEA = .04$; $SRMR = .03$). Furthermore, Cronbach's alpha coefficient was acceptable for full scale ($\alpha = .73$).

Cohesion. The Short Spanish version of GEQ (Carron, Widmeyer, & Brawley, 1985) developed by Leo, González-Ponce, Sánchez-Oliva, Pulido, and García-Calvo (2015) was used to assess team cohesion. This inventory of 12-item comprises four factors, GI-T (i.e., "Team members are united in their efforts to reach their performance goals in training sessions and matches"), GI-S (i.e., "Team members would like to spend time together in situations other than training and games"), ATG-T (i.e., "On this team, I can do my best"), and ATG-S (i.e., "The team is one of the most important social groups I belong to"). Responses were rated on a nine-point scale ranging strongly disagree (1) to strongly agree (9). The CFA results with data from our study confirm this four-factor structure showing acceptable model fit ($\chi^2/df = 3.71$; $CFI = .94$; $TLI = .94$; $RMSEA = .06$; $SRMR = .04$). Furthermore, Cronbach's alpha coefficients were acceptable, obtaining values of .79 GI-T, .74 for GI-S, .74 for ATG-T and .71 for ATG-S.

Transactive Memory. A validation to the sport context of the Transactive Memory System Scale (Lewis, 2003) developed by Leo, González-Ponce, Sánchez-Oliva, Amado, and García-Calvo (2016) was used to assess transactive memory. This questionnaire of 15-item comprises three factors: specialization, credibility and coordination. In this paper, we were interested in the higher order dimension and not in the lower order dimensions. Example of transactive memory includes "Each team member has specialized knowledge of some aspect of the game". Players respond to all items on a five-point scale ranging from strongly disagree (1), to strongly agree (5). The CFA results with data from our study confirm this three-factor structure showing acceptable model fit ($\chi^2/df = 2.77$; $CFI = .96$; $TLI = .96$; $RMSEA = .05$; $SRMR = .03$). Furthermore, Cronbach's alpha coefficients were acceptable for both the three subscales ($\alpha = .68, .66, .71$, respectively) and full scale ($\alpha = .83$).

Collective Efficacy. To assess collective efficacy, the "Cuestionario de Eficacia Colectiva en Fútbol" (CECF, in English, "The Soccer Collective Efficacy Questionnaire"), developed by Leo et al. (2014), was used. This instrument starts with a stem phrase (i.e. "Our team's confidence in our capability to...") and has a total of 6 items that refer to some soccer situations (i.e. "...resolve games situations in the attacking phase"), which are grouped into a single factor. Responses were rated on a 5-point scale ranging bad (1) to excellent (5). The CFA results with data from our study confirm that all 26 items were

grouped into a single factor ($\chi^2 / df = 3.76$; $CFI = .97$; $TLI = .97$; $RMSEA = .06$; $SRMR = .04$). Furthermore, Cronbach's alpha coefficient was acceptable for full scale ($\alpha = .81$).

Procedure

We used a correlation methodology with a transversal design. The study received ethical approval from the University. All participants were treated according to the American Psychological Association ethical guidelines regarding consent, confidentiality, and anonymity of responses. Also, the measurement plan was announced to underage athletes and their parents, who decided their children's participation in the study. We carried out one assessment at the beginning of the season along three weeks and data collection took place at the clubs in group settings under the supervision of trained research assistants. Questionnaires were matched over time using a coding system to protect anonymity. Research assistants read the instructions first and encouraged participants to ask questions if they had any doubts that needed to be clarified. Participants completed the questionnaires in the changing room before the training session. This procedure took approximately 15-20 minutes. They completed the questionnaires individually, in the absence of their coach, in an atmosphere that ensured that they would not be distracted.

Data analysis

The SPSS 19.0 program was used to analyze the data. Statistical techniques employed were factor analysis, reliability analysis and descriptive analysis. We also used AMOS 18.0 software to test the structural equation model.

RESULTS

Descriptive statistics and Cronbach's alpha coefficients

Means, standard deviations, normality and Cronbach's alpha coefficients for each variable are presented in Table 1. Most scales demonstrated acceptable internal consistency (i.e., $\alpha > .70$). We examined data normality, obtaining skewness values between -1.23 and .79, kurtosis values between -1.44 and 1.78.

Regarding means, in general participants reported scores above the midpoint of the scale for role ambiguity, cohesion, transactive memory and collective efficacy. Participants also reported scores for role conflict which were under to the midpoint of the scale.

TABLE 1
Descriptive Statistics and Cronbach's Alpha Coefficients.

	<i>M</i>	<i>SD</i>	<i>Min</i>	<i>Max</i>	<i>Skewness</i>	<i>Kurtosis</i>	<i>α</i>
Role Ambiguity	7.68	1.05	3.67	9.00	-1.23	1.78	.83
Role Conflict	1.69	.56	3.58	9.00	.79	.39	.73
Group Integration-Task	7.04	1.50	1.67	9.00	-.81	.25	.79
Group Integration-Social	7.10	1.48	2.00	9.00	-.82	.63	.74
Individual Attractions to the Group-Task	7.61	1.17	3.33	9.00	-1.01	.99	.74
Individual Attractions to the Group-Social	6.98	1.64	1.33	9.00	-.98	.63	.71
Transactive Memory	4.11	.48	2.89	5.00	-.21	-.44	.83
Collective Efficacy	3.95	.50	2.17	5.00	-.52	.77	.81

Structural equation modeling

In order to determine the prediction capacity of the variables of our study, we used a structural equation modeling. With the aim to accept or reject a model, the most appropriate method is to use a combination of various fit indexes, as there is no consensus among researchers about which is the best index for this kind of analysis (Hoyle & Panter, 1995). Taking into account the contributions of some authors (Bentler, 1990; Bollen & Long, 1993), in this study, we used the following fit index: chi-square divided by degrees of freedom (χ^2/df), the comparative fit index (*CFI*), the Tucker Lewis index (*TLI*), the root mean square error of approximation (*RMSEA*) and Standardized Root Mean Square Residual (*SRMR*). As chi-square is very sensitive to sample size (Jöreskog & Sörbom, 1996), we used the ratio between chi-square and the degrees of freedom (χ^2/df), which is considered acceptable when it is lower than 5 (Bentler, 1990). According to Schumacker and Lomax (1996), the incremental indexes (*CFI* and *TLI*) indicate acceptable fit when they obtain values of .90 or higher. Regarding the *RMSEA* and *SRMR*, .08 has been established as an acceptable cut-off point (Hu & Bentler, 1999).

In this manner, a measuring model was tested first through the estimation method of maximum authenticity. As the Mardia coefficient was elevated (29.94), a bootstrapping method was also used which allowed to assume that the estimators were not affected by the lack of multivariate normality (Byrne, 2001). The fit indexes indicated that the measuring model adequately described the data ($\chi^2/df = 1.83$; *CFI* = .94; *TLI* = .94; *RMSEA* = .06; *SRMR* = .05). Secondly, a structural equation model was developed through the estimation method of maximum authenticity along with the bootstrapping method. It has to be pointed out that the values of the attachment indexes were not sufficiently adequate ($\chi^2/df = 2.29$; *CFI* = .90; *TLI* = .90; *RMSEA* = .08; *SRMR* = .10).

Following Carron's cohesion model (Carron & Eys, 2012), the first level of the model established role ambiguity and role conflict as antecedents of the

four factors of group cohesion, that were introduced in the second level of the model. Next, transactive memory and collective efficacy were placed as consequences of group cohesion. Therefore keeping in mind the theoretic hypotheses and the confirmation of the measuring effects under the approach of Holmbeck (1997) through the SEM in four steps, we decided to include transactive memory in the first level and lastly on the last level collective efficacy.

Keeping in mind that the fit indexes were not ideal and that the social dimensions of the model were not relevant we decided to eliminate these variables. As a matter of fact, ambiguity and role conflict did not display significant values regarding the prediction of the two factors of social cohesion. Equally the predictive capacity of social cohesion on transactive memory and collective efficacy was not significant. Thus, following the same previous method the model of structural equations was developed through the estimation method of maximum authenticity along with the bootstrapping method. It has to be pointed out that in this case, once the two variables of the social dimension of cohesion was eliminated (ATG-S and GI-S), the values of the fit indexes were adequate ($\chi^2 / gl = 2.16$; $CFI = .93$; $TLI = .93$; $RMSEA = .06$; $SRMR = .06$).

In this manner, in the new model which can be referred to in Figure 2 it can be observed how the absence of role ambiguity positively predicts integration into the task group and with higher scores the individual attraction to the task group. Something similar occurs between the role conflict and cohesion, where the weights of regression are lightly more elevated over individual attraction to task group than over integration into the task group. Next it can be detected how both factors of task cohesion predict transactive memory in a positive manner with weights of regression significantly elevated. Lastly, transactive memory predicts collective efficacy with elevated values.

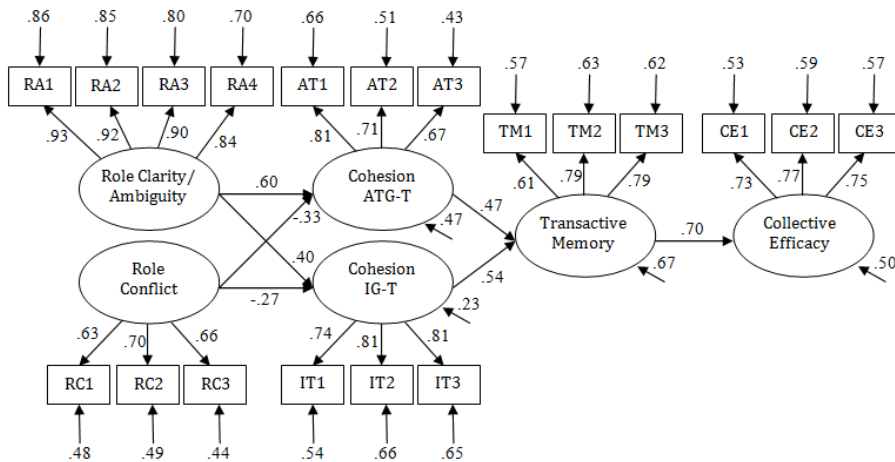

FIGURE 2: Structural equation model of the relationships among variables.

DISCUSSION

The aim of the study was to apply the conceptual model of cohesion among professional female sports groups examining role ambiguity and role conflict as antecedents of group cohesion and at the same time transactive memory and collective efficacy as consequences of it. A sufficient amount of studies exist that prove the importance of the psychological aspects in the development and optimization of resources that exist in work groups to improve its functioning (Carron & Eys, 2012). In that manner, this work allows to confirm that aspects such as role ambiguity and role conflict are negatively associated with union, attraction to and integration in a group. In turn, this group cohesion seems to manifest itself as a determining factor in the capacity of the group to share relevant knowledge among work colleagues and in the confidence in the group abilities to obtain optimal performance in regards to group work.

Despite the fact that Carron's cohesion model defends the existence of four factors in group cohesion, it has to be kept in mind that the variables role ambiguity and role conflict mention aspects related to the development of the tasks of a work group. This can explain the absence of significance in its relation with the social aspects of cohesion. Previously, other authors have already confirmed on a theoretical level that role ambiguity and role conflict are primarily going to condition the task dimensions of cohesion (Carron & Eys, 2012; Eys & Carron, 2001). Along this line, it has to be pointed out that neither the association of social cohesion and transactive memory and collective efficacy was significant, for which it has to be kept in mind that other factors exist that are closer linked to social aspects and others induce task aspects. Furthermore, previously Carron argued (1980) that in high level groups task cohesion is more significant that social cohesion. For this reason, it is necessary to highlight that the social aspects in work groups that seek maximum

productivity do not seem to show as much importance in regards to the factors that affect the to task to complete.

This fact also invited us to readjust the hypothetical model uniquely with the task factors of cohesion (Carron & Eys, 2012; Eys & Carron, 2001). Furthermore, this idea was approved due to the fact that the index values that fit the initial model were not adequate when all factors of cohesion were introduced. If we consider the results of the final model, it can be observed that the members that perceived less role ambiguity showed higher levels of task integration and attraction. Additionally, the subjects that perceived a higher degree of role conflict showed lower levels of task cohesion (GI-T and ATG-T). This discovery makes sense from a conceptual point of view, because Carron confirmed in his model that fluid communication between the coach and the players in regards to the team objectives, team tasks and most of all clarity in the roles of team members have significant importance for cohesion (Carron & Eys, 2012; Cunningham & Eys, 2007). Equally, Eys and Carron (2001) and Bosselut et al. (2012) found an inverse relation between role ambiguity and factors of task cohesion in team sports. Furthermore, in both studies this relation was established among men as well as women, although it has to be kept in mind that the samples were smaller and they were not professional participants. Therefore our results confirm that ambiguity in task to complete and the conflict with the functions to carry out in professional female work groups is also negatively associated with union and strength of the group as a team.

The results of the study also tried to confirm transactive memory and collective efficacy as two positive consequences of cohesion. As we have commented earlier, given that transactive memory is related to the capacity to share knowledge among colleagues in specific task situations to complete, it was closely associated with to more strength towards task factors of cohesion. Like it can be perceived in the model of structural equations, ATG-T as well as GI-T showed a prediction with elevated values of transactive memory. Ren and Argote (2011) have already revised the most important studies of transactive memory and identified an aspect that was very closely associated with cohesion, that is communication within the group as a relevant factor in the development of transactive memory when it comes to improve the performance of work groups.

Therefore, when team members feel strong bonds with the group and perceive willingness to cooperate and work as a team they could display a great predisposition to learn and acquire knowledge of their colleagues. That is to say that it can favor the existence of greater shared knowledge for the tasks to complete. This is relevant, because if every person knows what every colleague can contribute to the group and who can carry out which task the best, the

functioning of the group is being optimized. Furthermore, these discoveries are in line with the conceptual model of cohesion (Carron and Eys, 2012) that highlighted the necessity to achieve high levels of cohesion in a group to optimize its functioning and performance (Carron et al., 2002; Eys et al., 2015; Leo et al., 2014). In this sense, this union and cooperation in the development of tasks enables a stronger transactive memory among colleagues, which enables the resolution of problems and situations that appear in the group in the course of executing tasks.

Lastly, another key subject of the study was the relation that is established between cohesion and collective efficacy. Previous studies already have confirmed the importance to keep a group unified with the objective to favor the confidence in its capacity to obtain better performance (Heuzé et al., 2006; Kozub & McDonnell, 2000; Leo et al., 2014; Spink, 1990). In fact, within the cohesion model, collective efficacy was pointed out as one of the most important consequences of group cohesion (Carron & Eys, 2012).

If we observe the structural equation model and keep the theoretical hypotheses of transactive memory in mind that identifies efficacy as one of the direct benefits / advantages of transactive memory (Lewis, 2003), we consider that transactive memory could have an impact on the levels of collective efficacy. Equally, we checked the effects of mediation conducted under the approach of Holmbeck (1997), where it was observed that the predictive capacity of team cohesion over collective efficacy was greater through the mediation of transactive memory. Therefore we decided to include transactive memory on a first level and finally in the last level collective efficacy was introduced.

This way two levels for the consequences of group cohesion were established where transactive memory was profiled as a mediator between group cohesion and collective efficacy. As we were able to observe, the members that perceived greater attraction and integration to task and greater development of transactive memory in their teams revealed greater confidence in a successful development in the tasks to complete. Similar results were found by Leo et al. (2014) in soccer teams, where task cohesion was found as primary predictor of collective efficacy (Kozub & McDonnell, 2000).

CONCLUSIONS

In accordance with the objectives and the hypothesis sought in this study, it can be confirmed that we have completed an approximation from the conceptual model of cohesion to achieve an understanding of the group processes that take place in professional female work groups. This way the established hypothesis can be confirmed, because role ambiguity and role conflict were shown as negative antecedents of group cohesion. Equally, task

cohesion was shown as determining factor in the development of transactive memory in collective efficacy that was revealed by members of the group. These results can serve as support for leaders of organizations and work groups with employee characteristics similar to those of the study.

One of the limitations of the study is that is it a transversal work and results can be influenced by events close to the moment of measurement. Keeping in mind the objective of the study, it would be interesting to conduct future work with a longitudinal methodology to observe how the variables develop over the course of a season. Another limitation of the study make reference to the multidimensional approximation of variables such as role ambiguity, role conflict or transactive memory that would provide more information, although it would make the understanding more difficult for the reader due to the number of variables.

Despite of that, the study combined different constructs that have not been considered together in an athletic environment, such as roles and transactive memory, and can be a relevant starting point for future investigations. Furthermore, this work contributes results that invite to continue analyzing the behavior of women in work groups of the same gender with the objectives productivity and performance. Therefore it can be interesting to realize intervention work focused on the clarification of roles as a measure to obtain better team work and great optimization of group resources.

In conclusion, the results of this study construct a series of practical implications that can be very useful for leaders of work groups similar to the ones of this investigation. The importance to clarify the roles of members of a female work team, given the negative results established in regards to task cohesion, can be a priority for someone in charge of this type of collective. The work of the clear and precise explication and transmission of personal functions seems to have great significance. Furthermore, the results show that the group members that have more clarity and less conflict in their functions that need to be completed and further perceive greater integration and individual attraction to the task group present better knowledge among colleagues and greater confidence when facing competitive situations. Therefore the results of this study suggests that female sport groups present similar characteristics as other work groups, because their directors and leaders that encourage union, cooperation and group work have impact on the optimization of the functioning of the group, through greater shared knowledge and confidence in the abilities of each group member. If the leaders achieve to increase the knowledge about what every player has to do and increases the confidence in the capacities to develop for the group, they will make way to optimize the resources of the group, given the tight link of the factors with the performance of it.

REFERENCES

- Bandura, A. (1986). *Social foundations of thought and action: A social cognitive theory*. Englewood Cliffs, NJ: Prentice-Hall.
- Beal, D. J., Cohen, R. R., Burke, M. J., & McLendon, C. L. (2003). Cohesion and performance in groups: a meta-analytic clarification of construct relations. *Journal of Applied Psychology, 6*, 989–1004. doi:10.1037/0021-9010.88.6.989
- Beauchamp, M. R. (2007). Efficacy beliefs within relational and group contexts in sport. In S. Lavalley & D. Jowett (Eds.) *Social psychology in sport*, pp. 181–193. Champaign, IL: Human Kinetics.
- Beauchamp, M. R., & Bray, S. R. (2001). Role ambiguity and role conflict within interdependent teams. *Small Group Research, 32*, 133–157. doi:10.1177/104649640103200202
- Beauchamp, M. R., Bray, S. R., Eys, M. A., & Carron, A. V. (2002). Role ambiguity, role efficacy, and role performance: Multidimensional and mediational relationships within interdependent sport teams. *Group Dynamics: Theory, Research, and Practice, 6*, 229–242. doi:10.1037/1089-2699.6.3.229
- Beauchamp, M. R., Bray, S. R., Fielding, A., & Eys, M. A. (2005). A multilevel investigation of the relationship between role ambiguity and role efficacy in sport. *Psychology of Sport and Exercise, 6*, 289–302. doi:10.1016/j.psychsport.2004.03.002
- Bentler, P. M. (1990). Comparative fit indexes in structural models. *Psychological Bulletin, 107*, 238–246. Retrieved from <http://escholarship.org/uc/item/6cn677bx>
- Bollen, K. A., & Long, J. S. (1993). *Testing Structural Equation Models*. CA: Sage Publication.
- Bosselut, G., McLaren, C. D., Eys, M. A., & Heuzé, J. P. (2012). Reciprocity of the relationship between role ambiguity and group cohesion in youth interdependent sport. *Psychology of Sport and Exercise, 13*(3), 341–348. doi:10.1016/j.psychsport.2011.09.002
- Byrne, B. (2001). *Structural equation modeling with AMOS: Basic concepts, applications, and programming*. Mahwah, NJ: Erlbaum.
- Carron, A. V. (1980). *Social psychology of sport*. Ithaca, NY: Movement.
- Carron, A. V., Brawley, L. R., & Widmeyer, W. N. (1998). The measurement of cohesiveness in sport groups. In J. L. Duda (Ed.) *Advances in sport and exercise psychology measurement*, pp. 213–226. Morgantown, WV: Fitness Information Technology.
- Carron, A. V., Colman, M. M., Wheeler, J., & Stevens, D. (2002). Cohesion and performance in sport: A meta analysis. *Journal of Sport & Exercise Psychology, 24*, 168–188.

- Carron, A. V., & Eys, M. A. (2012). *Group Dynamics in Sport* (4th ed.). Morgantown, WV: Fitness Information Technology.
- Carron, A. V., Widmeyer, W. N., & Brawley, L. R. (1985). The development of an instrument to assess cohesion in sport teams: The Group Environment Questionnaire. *Journal of Sport Psychology*, 7, 244–266.
- Cunningham, I. J., & Eys, M. A. (2007). Role ambiguity and intra-team communication in interdependent sport teams. *Journal of Applied Social Psychology*, 37, 2220–2237. doi:10.1111/j.1559-1816.2007.00256.x
- Eys, M. A., & Carron, A. V. (2001). Role ambiguity, task cohesion, and task self-efficacy. *Small Group Research*, 32, 356–373. doi:10.1177/104649640103200305
- Eys, M. A., Ohlert, J., Evans, M. B., Wolf, S. A., Martin, L. J., Van Bussel, M., & Steins, C. (2015). Cohesion and performance for female and male sport teams. *The Sport Psychologist*, 29, 97–109. doi:10.1123/tsp.2014-0027
- Filho, E., Tenenbaum, G., & Yang, Y. (2015). Cohesion, team mental models, and collective efficacy: towards an integrated framework of team dynamics in sport. *Journal of Sports Sciences*, 33, 641-653. doi: 10.1080/02640414.2014.957714
- Fransen, K., Decroos, S., Vanbeselaere, N., Vande Broek, G., De Cuyper, B., Vanroy, J., & Boen, F. (2015). Is team confidence the key to success? The reciprocal relation between collective efficacy, team outcome confidence, and perceptions of team performance during soccer games. *Journal of Sports Sciences*, 33, 219-231. doi:10.1080/02640414.2014.942689.
- Fuster-Parra, P., García-Mas, A., Ponseti, F. J., & Leo, F. M. (2015). Team performance and collective efficacy in the dynamic psychology of competitive team: A Bayesian network analysis. *Human Movement Science*, 40, 98-118. doi:10.1016/j.humov.2014.12.005
- Heuzé, J. P., Raimbault, N., & Fontayne, P. (2006). Relationships between cohesion, collective efficacy and performance in professional basketball teams: An examination of mediating effects. *Journal of Sports Sciences*, 24, 59–68. doi:10.1080/02640410500127736
- Hollingshead, A. B. (2001). Cognitive interdependence and convergent expectations in transactive memory. *Journal of Personality and Social Psychology*, 81, 1080–1089.
- Holmbeck, G. N. (1997). Toward terminological, conceptual, and statistical clarity in the study of mediators and moderators: examples from the child-clinical and pediatric psychology literatures. *Journal of Consulting and Clinical Psychology*, 65, 599–610. doi:10.1037/0022-006X.65.4.599
- Hoyle, R. H., & Panter, A. T. (1995). Writing about structural equation models. In R. H. Hoyle (Ed.) *Structural equation modeling: Concepts, issues, and applications*, pp. 158–176. Thousand Oaks, CA: Sage.

- Hu, L., & Bentler, P. M. (1999). Cutoff criteria for fit indexes in covariance structure analysis: Conventional criteria versus new alternatives. *Structural Equation Modeling: A Multidisciplinary Journal*, 6, 1–55.
doi:10.1080/10705519909540118
- Jöreskog, K., & Sörbom, D. (1996). *LISREL 8: User's Reference Guide*. Chicago, IL: Scientific Software International Inc.
- Kozlowski, S. W. J., & Bell, B. S. (2003). Work groups and teams in organizations. Psychology. In W. C. Borman, D. R. Ilgen, & R. J. Klimoski (Eds.) *Comprehensive Handbook of Psychology: Industrial and Organizational*, pp. 333–375. New York: Wiley.
- Kozub, S. A., & McDonnell, J. F. (2000). Exploring the relationship between cohesion and collective efficacy in rugby teams. *Journal of Sport Behavior*, 23, 120–129.
- Leo, F. M., González-Ponce, I., Sánchez-Miguel, P. A., Ivarsson, A., & García-Calvo, T. (2015). Role ambiguity, role conflict, team conflict, cohesion and collective efficacy in sport teams: A multilevel analysis. *Psychology of Sport and Exercise*, 20, 60–66. doi:10.1016/j.psychsport.2015.04.009
- Leo, F. M., González-Ponce, I., Sánchez-Oliva, D., Amado, D., & García-Calvo, T. (2016). *Adaptation and validation into Spanish of the Transactive Memory System Scale (TMMS) in sport context*. Manuscript submitted for publication.
- Leo, F. M., González-Ponce, I., Sánchez-Oliva, D., Pulido, J. J., & García-Calvo, T. (2015). Adaptation and validation in Spanish of the Group Environment Questionnaire (GEQ) with professional football players. *Psicothema*, 27(3). doi:10.7334/psicothema2014.247
- Leo, F. M., Sánchez-Miguel, P. A., Sánchez-Oliva, D., Amado, D., & García-Calvo, T. (2014). Análisis de los procesos grupales y el rendimiento en fútbol semi-profesional [Analysis of the group process and the performance in semi-professional soccer]. *Revista Internacional de Medicina y Ciencias de la Actividad Física y del Deporte*, 14(53), 153–168. Retrieved from <http://cdeporte.rediris.es/revista/revista53/artanalisis451.htm>
- Lewis, K. (2003). Measuring transactive memory systems in the field: Scale development and validation. *Journal of Applied Psychology*, 88, 587–604.
doi: 10.1037/0021-9010.88.4.587
- Lewis, K., & Herndon, B. (2011). Transactive memory systems: Current issues and future research directions. *Organization Science*, 22, 1254–1265.
doi: 10.1287/orsc.1110.0647
- Lin, Y. H., & Chou, H. W. (2009). Exploring the formation of collective efficacy in college student learning teams. In T. Bastiaens et al. (Eds.) *Proceedings of World Conference on E-Learning in Corporate, Government, Healthcare, and Higher Education 2009*, pp. 2863–2870. Chesapeake, VA: AACE.

- Myers, N. D., Feltz, D. L., & Short, S. E. (2004). Collective efficacy and team performance: A longitudinal study of collegiate football teams. *Group Dynamics: Theory, Research, and Practice*, 8, 126–138.
doi:10.1037/1089-2699.8.2.126
- Nunnally, J. C., & Bernstein, I.H. (1994). *Psychometric theory* (3rd ed.). New York: McGraw-Hill.
- Paskevich, D. M., Brawley, L. R., Dorsch, K. D., & Widmeyer, W. N. (1999). Relationship between collective efficacy and cohesion: Conceptual and measurement issues. *Group Dynamics: Theory, Research, and Practice*, 3, 210–222. doi:10.1037/1089-2699.3.3.210
- Ren, Y., & Argote, L. (2011). Transactive Memory Systems 1985–2010: An integrative framework of key dimensions, antecedents, and consequences. *The Academy of Management Annals*, 5(1), 189–229.
doi:10.1080/19416520.2011.590300
- Schumacker, R. E., & Lomax, R. G. (1996). *A beginner's guide to structural equation modeling*. Mahwah, NJ: Lawrence Erlbaum Associates. Inc.
- Solansky, S. T. (2008). Leadership style and team processes in self-managed teams. *Journal of Leadership & Organizational Studies*, 14, 332–341.
doi:10.1177/1548051808315549
- Spink, K. S. (1990). Group cohesion and collective efficacy of volleyball teams. *Journal of Sport & Exercise Psychology*, 12, 301–311.
- Tubre, T. C., & Collins, J.M. (2000). Jackson and Schuler (1985) Revisited: A Meta-Analysis of the relationships between role ambiguity, role conflict, and job performance. *Journal of Management*, 26, 155–169.
doi:10.1177/014920630002600104
- Zaccaro, S. J., Blair, V., Peterson, C., & Zazanis, M. (1995). Collective efficacy. In J. E. Maddux (Ed.) *Self-efficacy, adaptation, and adjustment: Theory, research, and application*, pp. 305–328. New York: Plenum Press.